

Smart Node Touch Switches

Model: TS.2S (HL)

Product Guidance



Table of Contents

Table of contents	2
1.About Touch Switches.....	3
2. Smart Node Touch Switch TS.2S (HL)	4
3. Basic Load explanation.....	5
3.1 Power Supply.....	5
3.2 Front-End Touch Board.....	8
4. Installation Guide.....	10
4.1 Power Supply Installation.....	10
4.2 Touch Board with the power supply	12
5. Operations.....	13
6. Installation – Special Case	16
5.1 Invertor Connections.....	16
5.2 Two-Way Connection.....	16
6. Declaration.....	18
7. GUARANTEE and WARRANTY period.....	19

1. About Touch Switches

This section gives you a brief introduction to the Touch Switches segment. The Touch Switches can replace the traditional switches. Using Smart Node Touch Switches, one can control all the lights, fans, device connected through the plug (AC, TV, phone charger and many more) connected to it. All the appliances can also be controlled using our remote.

Smart Node Touch Switches are modular. We have different models in different modular sizes like 6M, 4M and 2M. This Touch Switches are compatible with the Norisys electrical plates. In a single Norisys plate, we can add Smart Node Touch Board along with other Norisys accessories like 6A plug, 16A plug, USB sockets and many others.

We can also customize our Touch Switches to be compatible with other electrical plates of other major companies like Legrand, Schneider and many others. This customization is only done on a prior order to the company.

Smart Node Touch Switches are capable of regulating multiple loads from a single regulator present. This is a very unique feature of the Smart Node.

Smart Node has 8 different modules in Touch Switches: TS.8S1R, TS.8S, TS.4S1R, TS.4S, TS.2S (NL), TS.2S (HL), TS.1C and TS.1B.

The advantages of using the Smart Node Touch Switches are:

- All the loads can be operated with an IR remote also
- Multiple on-board dimming using a single regulator
- There is always a live reflection of the state of the loads on the Touch Switch even if the loads are operated using remote
- The Smart Node Touch Switches adds elegant beauty to the interior of any house
- There is no problem of Touch Switches reorganization during the night as there is an option to keep on the dim white light
- It is shock-proof and water-resistant
- It is compact so more accessories can be adjusted in less space
- It is retrofit

2. Smart Node Touch Switch TS.2S (HL)

Smart Node Touch Switch TS.2S (HL) can connect up to two loads. You can turn on/off and lock the appliances connected to it. The two loads are of the type heavy load. The combination of the load possible with TS.2S (HL) is described in the further sections.

Total Loads: 2

Modular: 2M

Colour Available: Black/White

Two-way possibility: 1 Heavy load

Invertor connection: Possible

Here, in TS.2S (HL) model:

2S indicates a total of 2 Touch Pads (a total of 2 loads)

There is no on-board regulator present here

3. Basic Load explanation

This section covers explanation about different types of load in TS.2S (HL). The Touch Switches consists of a Touch Board and a power supply module. These two parts are connected by a connector.

3.1 Power Supply

The front view of the power supply module of TS.2S (HL) is shown below:

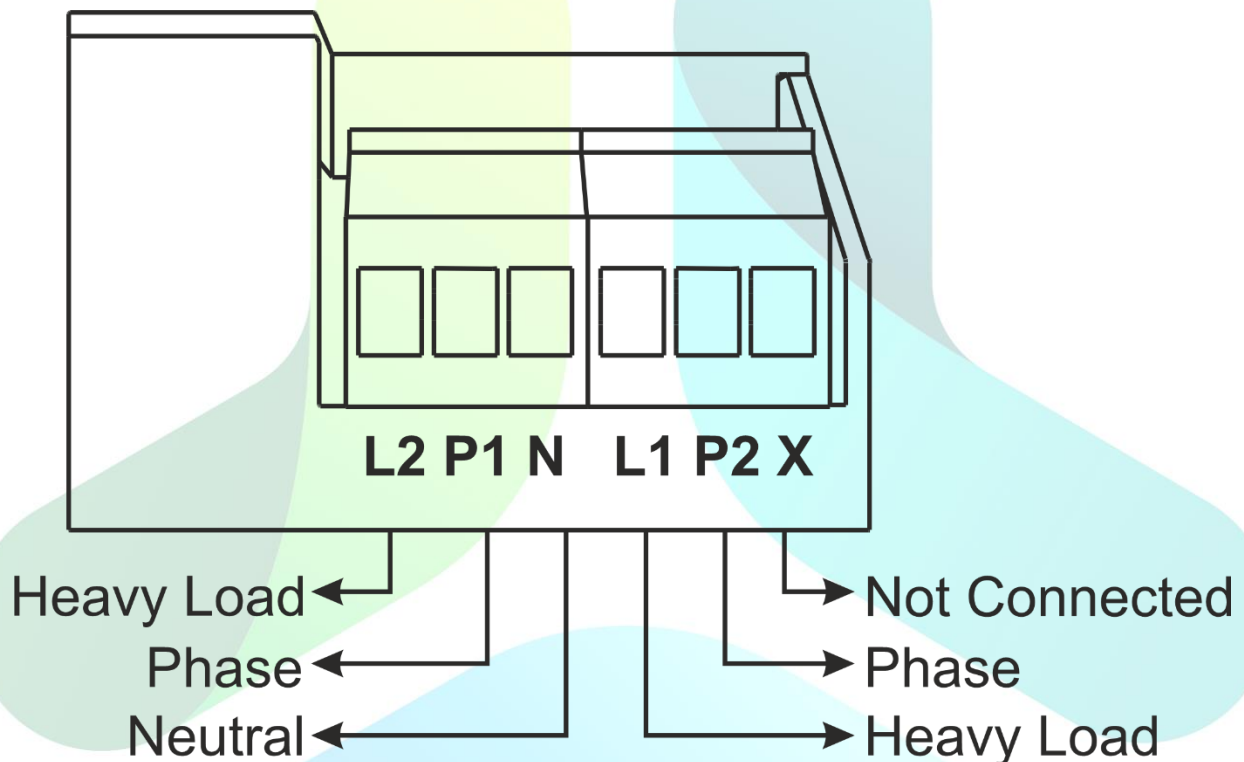

Here Ph indicates Phase (Live wire) input, N indicates Neutral input and HP indicates Heavy Phase input. The loads connected to the different output terminal are described in detail below:

➤ L- Heavy load

Here, the possible connections of loads are a light, fan, 6A plug, 16 A plug and many others.

- If a 16A plug is connected to this terminal then the examples of appliances that can be connected via plug are AC, geyser, fridge, motor and many other. We can only turn on/off the load connected to this terminal. A single load with a maximum load capacity of 2500 watt can be connected here.

- If a 6A plug is connected to this terminal then the examples of appliances that can be connected via plug are TV, phone-charger, light lamp and many more. We can only turn on/off the load connected to this terminal. A single load with a maximum load capacity of 1500 watt can be connected here.
- If a light with dimmable or non-dimmable driver is connected to this terminal, we can only turn on/off that light. We cannot dim the intensity of the light. A single light should not exceed 2000 watt. We do not recommend to group more than 8 LED lights with this load.
- If a fan is connected to this terminal, we can only turn on/off the fan. We cannot change the fan speed. Multiple fans with a maximum rating of 2000 watts can be connected here.

3.2 Front-End Touch Board

The front-end Touch Board is shown below:

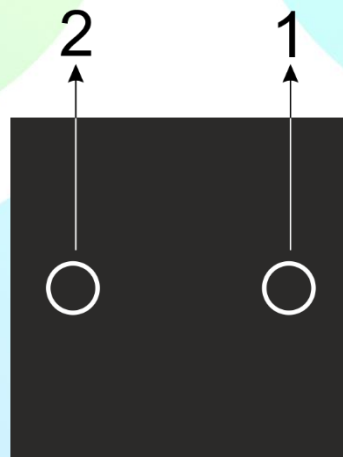

Here, the number indicates the load correspondence to the switch as shown below in the table:

Load <i>(Terminal on power supply)</i>	Touch Pad number	Default Remote Button
L1	1	1
L2	2	2

General Technical Specifications

Some general technical specifications of TS.2S (HL) module are given below

Input Voltage	110 to 240 VAC 50-60Hz	
Temperature	0 to 70°C Non-condense	
Minimum Life (per switch)	1,00,000 operations	
Humidity	20% - 80% RH non-condensing	
Material of the Touch Board	Acrylic	
Power Consumption	0.6W idle and <3W (On Full Load)	
Back End Size (L x W x H)	66mm x 50mm x 32.5mm	
Weight	200g	
Load-Wise Maximum Connection Capacity		
HL	Resistive	2500W
	Inductive	2000W
	Capacitive	2000W
Examples of Resistive loads are a filament-based lamp, iron, hair-dryer etc.		
Examples of Inductive loads are blender, mixer, fan, old tube light, motor etc.		
Examples of capacitive loads are LED lights, TV, set-top box, charger, SMPS, computer etc		

4. Installation Guide

Smart Node Touch Switch TS.2S (HL) installation can be divided into two parts: first is the power supply connection with the actual load wires and second is the connection of power supply with the front-end Touch Board. We will go deep into each section below.

The TS.2S (HL) box contains:

1. One front-end Touch Board
2. One power supply
3. One touch Switch Connector

4.1 Power Supply Installation

Before going through the steps of installing the hardware, let us first have a look at the normal wiring behind a switch-board where traditional switches are connected to the respective load to turn on or off that particular appliance.

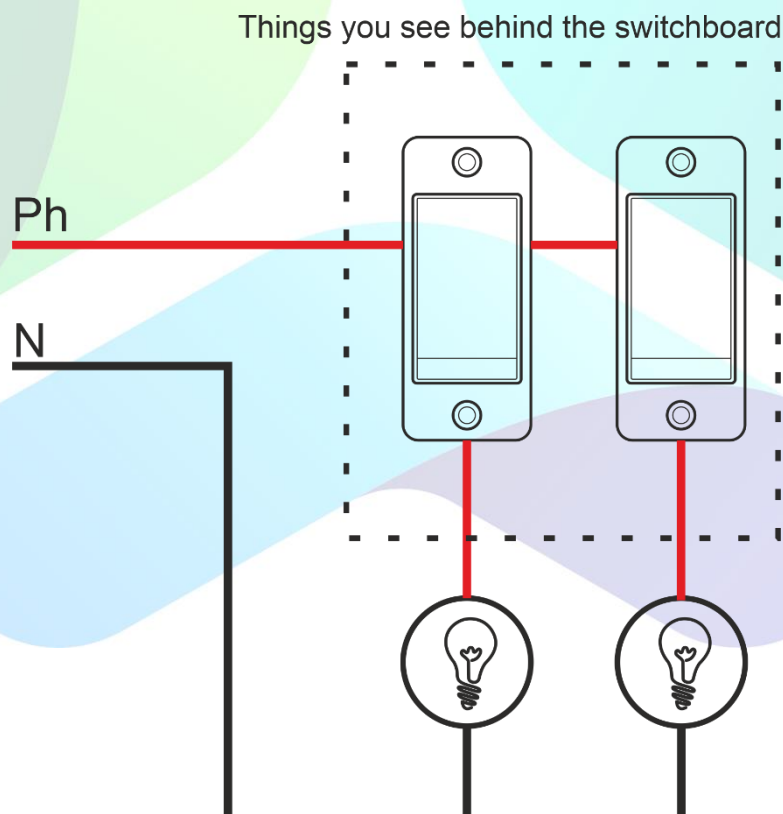

The next wiring diagram gives a basic explanation when a TS.2S (HL) is connected with the loads.

- 1) Please turn off the power by switching off the MCB for safety purpose. Then remove the front panel of the respective switchboard and open the screws of the switch-plate

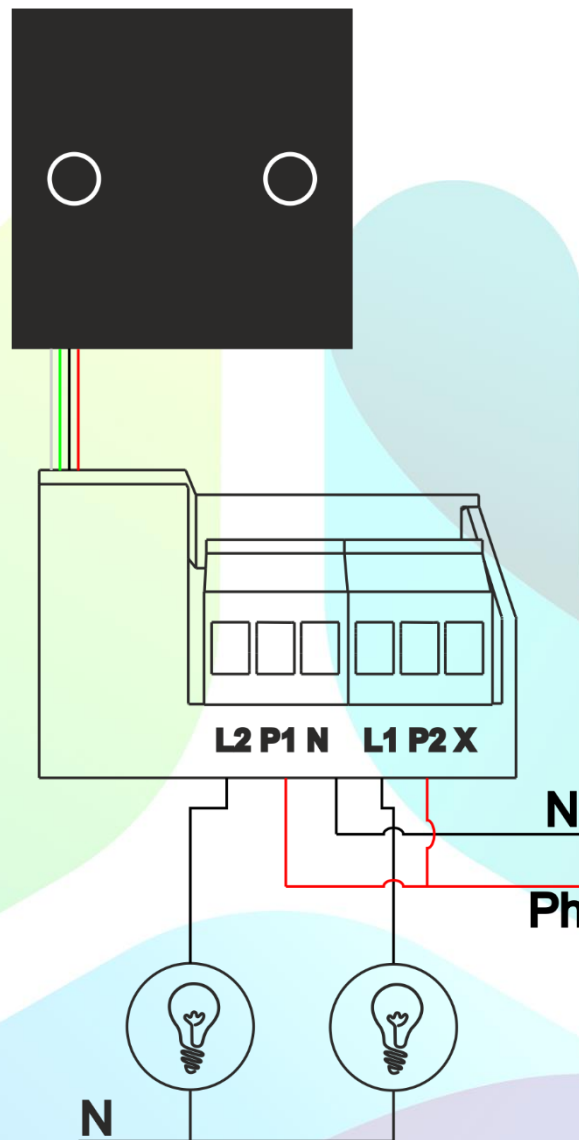

- 2) Identify the loads you wish to insert to Touch Switch. Disconnect the load wires from the traditional switches and also, remove the phase (Live) wire from the switches. Now, label the load wires as per the load connected for further easy identification.
- 3) We need to connect the wire of each load (which were removed from the switches) to each terminal of the power supply module as per the load type. The detailed information about the load is explained above.
- 4) Insert the Heavy Phase to P1 and P2 terminal, if any heavy load is connected to L1 and L2 terminal or else insert regular phase.
- 5) Insert the Neutral wire to N terminal.

4.2 Touch Board with the power supply

After successful wiring of the loads with the power supply, we now need to connect this power supply with the front-end Touch Board.

- 1) Now, we need to fit the Smart Node front-end Touch Board with the Norisys plate. Remove the last layer from the Touch Board and fit it with the back-plate of the Nosisys.
- 2) Insert the switch connector provided to the male connector block on the power supply located at the left side of the green terminals with the small arrow indicated on the switch connector facing in the front as shown in the figure below.
- 3) Now, we need to connect the other end of the connector with the Smart Node front-end Touch Board.
- 4) Now, insert the back-plate to the wall with the screws provided.
- 5) Now, insert the Norisys front plate.
- 6) Turn on the power by switching on the MCB.

For a detailed explanation, you can refer the video on our website.

5. Operations

The loads connected to TS.2S (HL) can be operated by two different ways at a time.

1) Physically touching the Touch Pads

One can physically touch the touch pads on the Touch Switch to turn on/off any load. The Blue indicates that the load is on. There is also a presence of dim white light to recognize the Touch Switches during the night.

2) Remote

Smart Node Touch Switches can be operated using our IR remote. The remote provided is universal. The remote layout is as shown below:



We can turn on/off any load using this remote. We can also set the fan speed or change the brightness of any dimmable light using this remote. Apart from these basic functions, the different types of features which are possible using remote are as follow:

Scene

We can set a total of 4 different scenes for a single Touch Switch on the remote. On pressing of the scene button, multiple actions on the Touch Switch can take place as per our creation. The scenes can be created by following a simple procedure using the remote. You can refer the video on our website for learning the procedure.

Touch Lock/Unlock

We can lock the Touch Switch using the remote. On locking it, all the operations on pressing the touch will become non-operational. We can again unlock it using the remote.

On/Off White Back Light

We can turn on/off the backend white light which is used for identifying the Touch Switch during the night using the remote.

Single Universal Remote

One Smart Node remote can work for multiple Touch Switches.

Master Control

Using a single button, you can turn on and turn off all the loads on a Touch Switch

Remote button learning

By default, all the buttons on the Touch Switch are assigned a number on the remote starting from 1. But, in certain condition, need arises when we need to change the assigned button on the remote. This can be done by following a simple procedure which can be learned by watching the related video on our website. A simple real-time example where the need arises to change the assigned button for one-touch is as shown below. Here, if 2 number is pressed from the remote, then Touchpad 2 on both the Touch Board will respond. Similarly, for Touchpad 3 and 4. So, it is better to assign a different button on the remote for TS.4S touch pads.

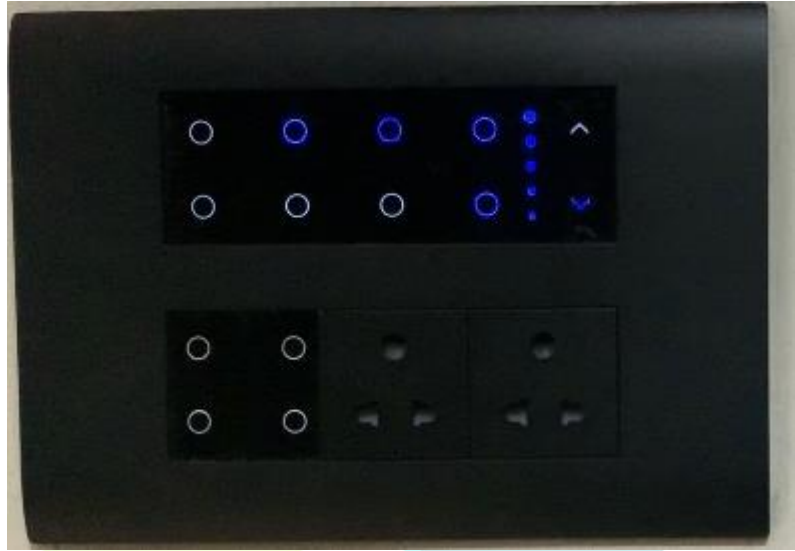

6. Installation – Special Cases

There are some special cases where the connection becomes a little bit complex. Some examples are:

6.1 Invertor Connection

If you wish to connect the loads connected with TS.2S (HL) to work with inverter, then it is mandatory to insert the Invertor phase wire to Ph terminal (P1) of the power supply. By default, the loads connected to L2 will be connected with the Invertor. If we wish to connect other loads of TS.2S (HL) with inverter, we need to connect the inverter phase with the Ph terminal as follows.

Loads	Ph Terminal
L2	P1
L1	P2

6.2 Two- Way Connection

In TS.2S (HL), a total of only one load is possible to make it work as two-way. The load connected with L1 can only be made two-way.

Two-way connection depends whether we have connected traditional switches or Smart Node Touch Switches on the other side.

The following wiring diagram shows a basic two-way connection.

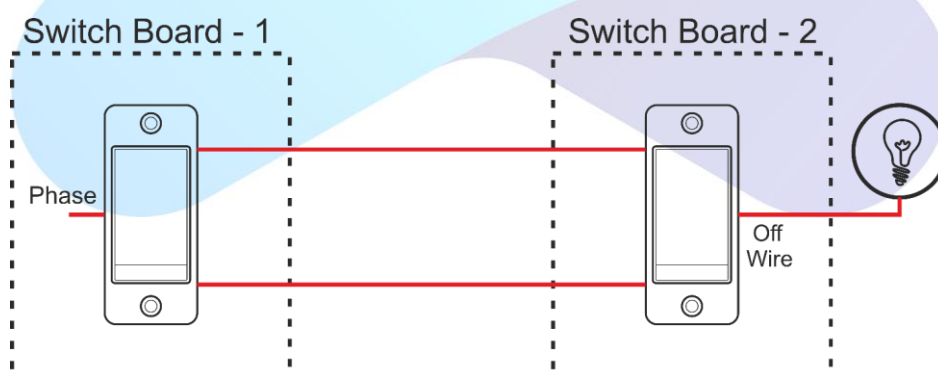

If Smart Node Touch Switches are connected on both sides, then the two-way connection is possible and the wiring diagram will be as follows

Switch Board 1

Switch Board 2

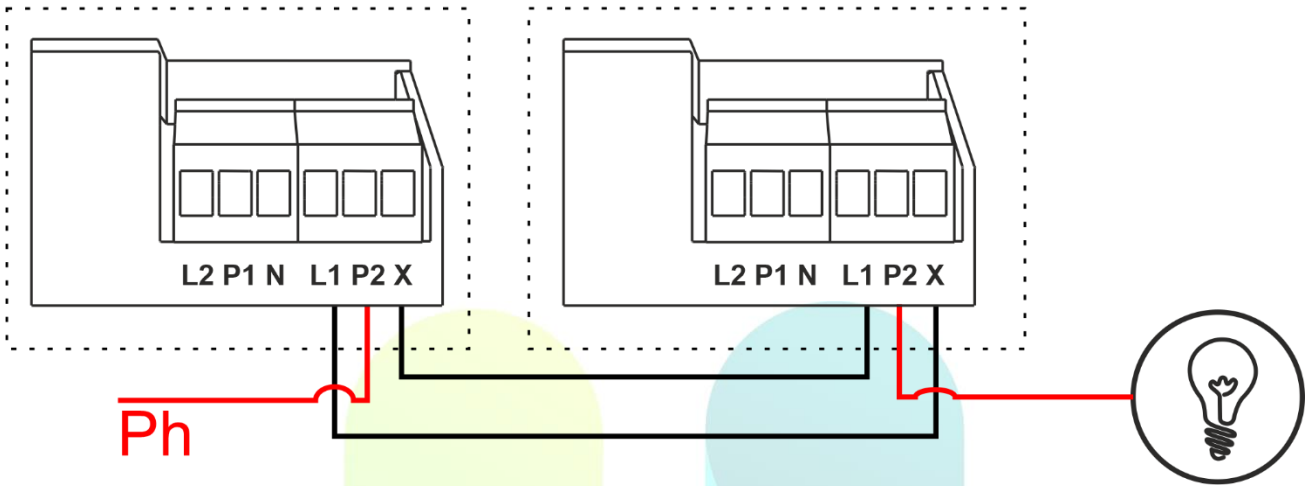

If traditional switches are connected on the other side, then the two-way connection is possible and the wiring diagram will be as follows

Switch Board 2

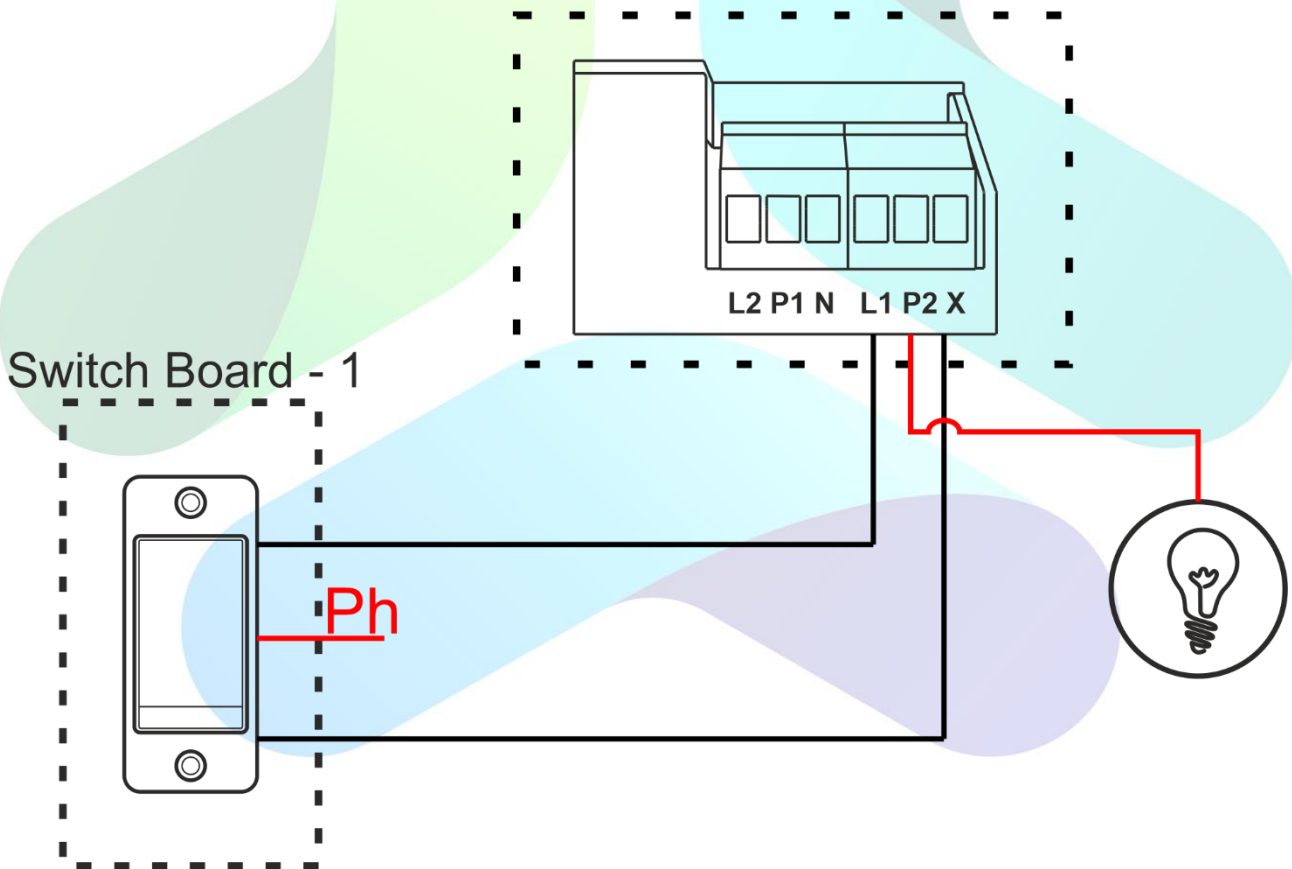

6. Declaration

All Smart Node products are proprietary of Smart Node Automation Private Limited. All rights reserved. Without prior approval of Smart Node Automation, reproduction, transfer, distribution or storage of contents in this document in any form is prohibited. Smart Node Automation operates a policy of ongoing development. Thus, Smart Node Automation reserves the right to make changes or improvements to the products described in this document without prior notice.

If you need further assistance, please write to us at support@smartnode.in or call us at +91-9327958744. You can also refer FAQs on our website for general doubts.

7. GUARANTEE and WARRANTY period

Smart Node offers seven years of free repairable warranty from the date of billing of the end client.

Smart Node will not be liable in any way towards damage caused to products by following:

- a) The guarantee or warranty period is expired.
- b) The serial number label is missing or unrecognizable.
- c) The product has been modified or repaired by any unauthorised service centre or personnel during its guarantee or warranty period.
- d) The defect was subject to abuse, improper use not conforming to product manual instructions, or environmental conditions more severe than those specified in the manual and specifications.
- e) Damage caused by user (including but not limited to breakage of the module, wrong installation, no electrical earthing)
- f) Spillages or moisture (including but not limited to exposure or contact with any liquid)
- g) Neglect
- h) Accidents including but not limited to improper voltage or power supply.
- i) Unauthorised modifications including but not limited to the opening of the module, changing wiring;
- j) Use of Smart Node products with incompatible or faulty equipment, using on higher loads;
- k) The defect was subject to Force Majeure, such as acts of God, flood, lightning, earthquake, war, vandalism, theft, brownouts or sags (damage due to low voltage disturbances).

If the customer's product is not covered under guarantee or warranty, Smart Node may offer repair services at customer's own cost.