

# Remote Device

Model no. **RD.2XXNX**

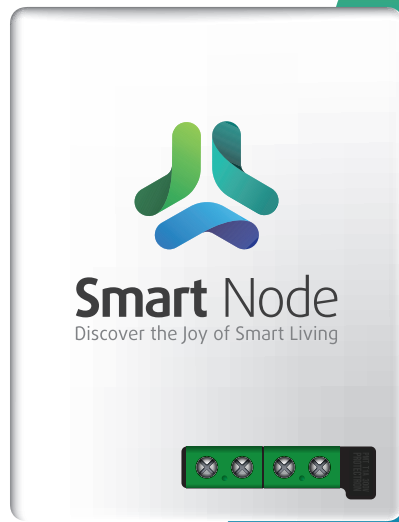



REMOTE  
DEVICE

**RD.2XXNX**

## OBJECTIVES

Touch remote control and manual control

## What it controls

Light, Set top box, TV, etc.



# FEATURES

- Anti-shock switching
- Compatible with capacitive switches
- Hassle free installation



## TECHNICAL ATTRIBUTES

Combination	0 Humming free fan 0 Dimmable load 2 Normal load 0 Heavy load
Operating input voltage	100 -240 VAC.
Supported frequency	50-60 Hz
Product weight ( gms )	97
Mode of operation	Physical and touch remote control
Max.load (fan)	N/A
Max.load (per dimmer, up to 3 LED)	N/A
Max.load (per normal load switch, up to 3 LED)	1500 watt
Max.load (per high load switch, up to 4 LED)	N/A
Operating temperature	0°C - 65°C non condense
Product size	70mm x 52mm x 25mm
Module size	2
Material	ABS
Shockproof	YES
Water resistance	NO

# CONNECTORS

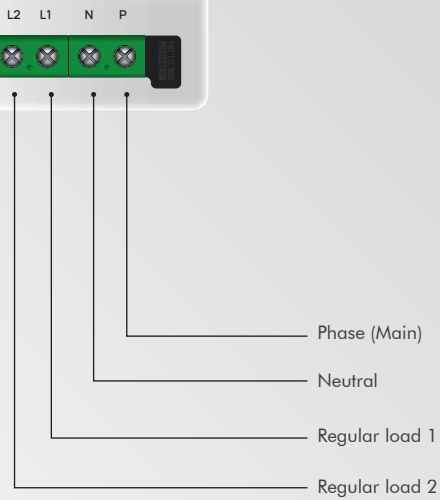
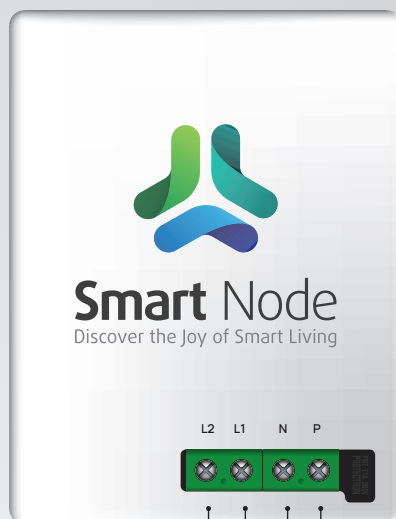

## Smartnode Automation Pvt. Ltd.

A-09-02-B, Kamdhenu Industrial Estate  
Opp, Gorwa Water Tank, Gorwa, Vadodara-390016

Tel.: +91 8200824126 | Email : [info@smartnode.in](mailto:info@smartnode.in)  
[www.smartnode.in](http://www.smartnode.in)