



Smart Node

Discover the Joy of Smart Living

smartnode.in

Smart Device

Model no. **SD.2XXNX**



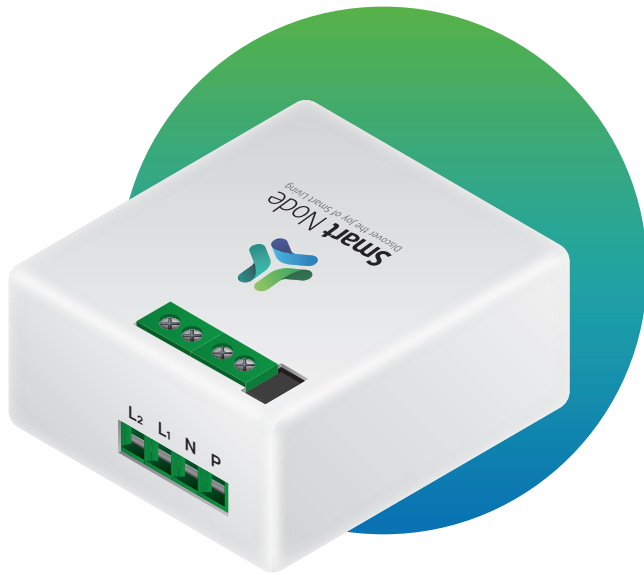

**SMART
DEVICE**
SD.2XXNX

OBJECTIVES

Voice control, Mood-based scene settings, Appliance scheduling, and Geo-location based control.

What it controls

Light, Set top box, TV, etc.



FEATURES

- Internet independent scheduling
- Anti-shock switching
- Compatible with traditional switches and capacitive switches
- OTA update support
- Hassle free installation

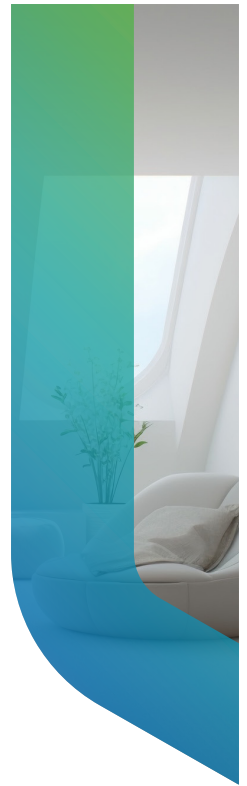

TECHNICAL ATTRIBUTES

Combination	0 Humming free fan 0 Dimmable load 2 Normal load 0 Heavy load
Operating input voltage	100-240 VAC.
Supported frequency	50-60 Hz
Communication protocol	Wi-Fi 2.4 GHz 802.11 b/g/n
Mode of operation	Physical, Voice, Mobile app
Max.load (fan)	N/A
Max.load (per dimmer, up to 3 LED)	N/A
Max.load (per normal load switch, up to 3 LED)	1500 watt
Max.load (per high load switch, up to 4 LED)	N/A
Wi-Fi signal strength min	>50%
Min. internet speed required	512Kbps
Data consumption	<3Mb/month
Operating temperature	0°C-65°C non condense
Product size	55mm X 24mm x 49mm
Module size (product size)	2
Material	ABS
Shockproof	No
Water resistance	No

CONNECTORS

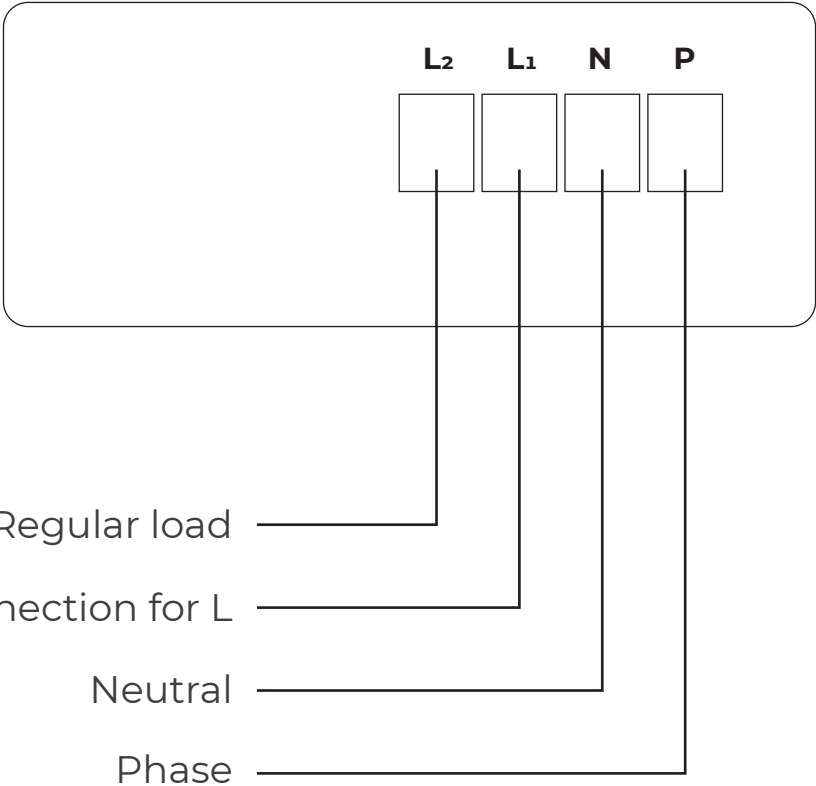

Smart Node Automation Pvt. Ltd.

A-09-02-B, Kamdhenu Industrial Estate
Opp, Gorwa Water Tank, Gorwa, Vadodara-390016
Tel.: +91 8200824126 | Email : info@smartnode.in
www.smartnode.in